



**A MOMENT OF RESPITE: FINDING OPPORTUNITIES  
TO HELP THE WORKFORCE RECENT AND  
READJUST THE MOOD**

**BY**

**QING LIU**

**A THESIS SUBMITTED IN PARTIAL FULFILLMENT  
OF THE REQUIREMENTS FOR  
THE DEGREE OF MASTER OF FINE ARTS IN DESIGN  
COLLEGE OF DESIGN**

**GRADUATE SCHOOL, RANGSIT UNIVERSITY**

**ACADEMIC YEAR 2021**

Thesis entitled

**A MOMENT OF RESPITE: FINDING OPPORTUNITIES  
TO HELP THE WORKFORCE RECENT AND  
READJUST THE MOOD**

by  
QING LIU

was submitted in partial fulfillment of the requirements  
for the degree of Master of Fine Arts in Design

Rangsit University  
Academic Year 2021

---

Assoc. Prof. Pisrapai Sarasalin  
Examination Committee Chairperson

Assoc. Prof. Eakachat Joneurairatan  
Member

---

Assoc. Prof. Pakorn Prohmvitak  
Member and Advisor

Approved by Graduate School

(Asst.Prof.Plт.Off. Vanee Sooksatra, D.Eng.)

Dean of Graduate School

August 10, 2021

## Acknowledgements

The research work of this thesis completed under the careful guidance of the teachers of Rangsit University. And thank my thesis advisors Ajarn David, Ajarn Tnop, Ajarn Sridhar, Ajarn Pisrapai.

In the process. The mentors made guiding opinions and suggestions on the research direction of my thesis.

Besides, I would also like to thank my friends and authors in the references, I am pleased to meet everyone, I will continue to move forward.



Qing Liu  
Researcher

6205584 : Qing Liu  
 Thesis Title : A Moment of Respite: Finding Opportunities to Help the  
 Workforce Recent and Readjust the Mood  
 Program : Master of Fine Arts in Design  
 Thesis Advisor : Assoc. Prof. Pakorn Prohmvitak

### Abstract

People are often affected by situations in their daily life and the proportion of mental problems generally increases in society. In the past twenty years, the global population has been increasing at an amazing speed. An increasing number of people are seeking opportunities for a better life, so they decide to migrate into high-density cities for life and work, with more than half of the world's population currently living in urban areas. People who live in cities are more likely to have mood or anxiety disorders. Living in a speed-driven workplace environment allows people to enjoy efficiency as well as to suffer from physical and mental health issues like pressure and anxiety.

In the workplace, employees are trying to adapt to their working environment and at the same time, they are inhibiting their own emotions. Emotion affects productivity and working efficiency. If the surrounding is a high-pressure environment that creates noise and a bad mood, people find it hard to balance between the inner status and the surrounding.

The author's proposal for this issue is to intervene with the breathing space in the working district by designing a seating unit that is fully enclosed to help people alleviate their anxiety before it accumulates to a certain disorder level.

(Total 27 pages)

Keywords: Stress, Workplace, Mood, Release, Breathing, Space

Student's Signature.....Thesis Advisor's Signature.....

## Table of Contents

	<b>Page</b>
<b>Acknowledgements</b>	<b>i</b>
<b>Abstract</b>	<b>ii</b>
<b>Table of Contents</b>	<b>iii</b>
<b>List of Tables</b>	<b>v</b>
<b>List of Figures</b>	<b>vi</b>
<b>Chapter 1 Introduction</b>	<b>1</b>
1.1 Background and Significance of the Problem	1
1.2 Research Objective	1
<b>Chapter 2 Literature Review</b>	<b>2</b>
2.1 User needs research	2
2.2 Case study	3
2.2.1 Please be Seated Project Analysis	3
2.2.2 WC Who Cares Project Analysis	5
2.2.3 Hush felt pod Project Analysis	6
2.2.4 Work bays VITRA Analysis	7
<b>Chapter 3 Research Methodology</b>	<b>9</b>
3.1 Investigate and observe data	9
3.2 Design evolution and thinking process	10
3.2.1 Size Analysis	10
3.2.2 Materials and Methods	15
3.2.3 Prototype of the design	16

**Table of Contents (continued)**

	<b>Page</b>
<b>Chapter 4 Final Design</b>	<b>19</b>
4.1 Product details	19
4.2 Product application and future development possibilities	23
<b>Chapter 5 Conclusion and recommendations</b>	<b>25</b>
5.1 Conclusion	25
<b>References</b>	<b>26</b>
<b>Biography</b>	<b>27</b>



## List of Tables

	<b>Page</b>
<b>Tables</b>	
3.1 The list think are the most important elements needed in this space	9



## List of Figures

<b>Figures</b>	<b>Page</b>
2.1 Project Please Be Seated, Broadgate	4
2.2 Project WC Who Cares	6
2.3 Project Hush felt pod	7
2.4 Work bays VITR	8
3.1 Data reference of chair	11
3.2 Data reference for cabinet	12
3.3 The sketch of a seating pod with a closed shape	13
3.4 Model of 1:100	13
3.5 3 Dimensional drawing of each part	14
3.6 Three dimensional view	14
3.7 Example of wood as a material used	15
3.8 Example of leather as a material used	16
3.9 Color psychology	16
3.10 The 3D design of the exterior	17
3.11 The 3D design of the exterior	17
3.12 The computer design of the prototype showing the circumstance of the designed seat	18
4.1 Storage area supporting various usage of the designed seat	19
4.2 The seating area incorporated with storage areas, which provide more comfortable space	21
4.3 The mockup illustrating how to use the designed seat	21
4.4 A prototype of the seat and its interior design	22
4.5 A prototype showing how to relax with the design seat	22



**List of Figures (continued)**

	<b>Page</b>
<b>Figures</b>	
4.6 The finished prototype of a seating unit pod that is fully enclosed	23



# **Chapter 1**

## **Introduction**

### **1.1 Background and Significance of the Problem**

One-third of a person's life is spent in their workplace. With that high number, 50% of office workers still take sick leave because of mood. 52% of the office workers have lost their temper on the job, 45% cries at work, 60% still not have time to express their true self, and 36% think they have too much work and need to take a break (Simpkin, 2020). Study the behavior and situations of the office workers by gathering the information from the websites and collect their needs related to the office environment to learn the problems faced by the office workers. A modern workplace is like an overloaded factory under pressure in today's rapid development era. Accompanied with high pace and high efficiency, each employee is like a top spinning in high-speed. Voice, interference, endless e-mails, and constant notification sounds in the App, all inevitably impact the work experience. Under such an environment, it is hard to find a balance between the inner state and the surrounding environment.

### **1.2 Research Objective**

1.2.1 To study how to maximize the usage of a seating pod to help the office workers recenter and readjust their mood.

1.2.2 To create a prototype of a fully enclosed seating pod.

## **Chapter 2**

### **Literature Review**

The workplace is the place where people finish their work, so the layout of the office determines whether employees can create a space that is more conducive to the completion of work.

#### **2.1 User needs research**

The space layout of the office is divided into unit type, single room type, open type, and mixed type. At present, with the rapid rise of open shared space, the employees work in a more open space. Shared office design has become an increasingly popular model for companies to save space, budget and management costs, as well as gathering companies of the same type. With equipment and supplies of shared office, and even common breakout areas, the shared office environment provides more opportunities for staff to interact.

As space becomes larger, the partition that hinders hearing and vision is also removed. After the partition is removed, the employees can communicate about their work more easily at anytime and anywhere in their seats, and a sense of cooperation is virtually provided (Augustin, 2013).

However, it is worth noting that in this environment, it is difficult to focus on the work on the one hand and plan how to get the job done better while ignoring external interference on the other. Usually, in such an environment, it is difficult for

the employees to strike a balance with their surroundings, and their psychology will naturally be affected by the messages conveyed in the working environment.

The office workers are often influenced by their mood that, in turn, affects their productivity and working efficiency. The current office is mostly open, so it is hard to keep a balance between the surroundings and inner heart. The office workers often inhibit their mood since it is not easy to express their true mood in an open space. For this reason, the author aimed to create a respite space to help these office workers.

Office factors affect people's mood, which highlights the importance of quietness and privacy. When feeling stressed, it may be important to leave the stressful environment appropriately. A breathing space for one person provides quietness and freedom from external disturbances in a closed environment. If emotions change with factors in the workplace, the elements in the breathing space may in turn transform a person's emotions.

## **2.2 Case study**

### **2.2.1 Please Be Seated Project Analysis**

The design is consist of curves of varying heights, which looks like waves layer after layer from a distance. The wavy lines produce an emotional connection that can create excitement. The frequency and density of waves are also inseparable from emotion. For example, the famous designer Gaudi's Casa Mira, takes the wave shape to the extreme, with its wavy exterior and white stone facade.

The seating is formed within rising wavy curve, creating a sense of security when one's back is directly in front of hard objects. Dining in such a seat makes people

feel comfortable since our backs are well protected and we don't worry about being attacked. The most popular seats in restaurants are those facing the wall, which protect the back of the customer.

When placed on a busy street, it provides more than just a seat for resting, but it is more of an interaction with pedestrians. Either sitting or lying down, it creates the resting space in the public areas of city. The active exploration of urban space is the creative development for the city and will bring new thinking and new values to the city.

“Please Be Seated” was designed (Figure 2.1) to integrate into daily life and to construct a part of the city. It also breaks the space boundaries, starting to transform the surrounding space. The material with coating was chosen for easy cleaning and frequent use (Paul Cocksedge Studio, 2019).



Figure 2.1 Project Please Be Seated, Broadgate

Source: Paul Cocksedge Studio, 2019

### 2.2.2 WC Who Cares Project Analysis

Inspiration comes from release rather than depression. Transform a private room in the office into a small compartment where performances can be performed and set up a stage, when the door is locked, the people inside can freely dance and dress up, sing or dance to their favorite music, and escape the feeling of being watched in the office (Figure 2.2). It allows people to show their truest selves and release their inner tensions. If you keep being watched by other people in the office, your functions will be out of balance, which is a response to the suffocating surveillance in the open office (Tual, 2020).

When employees feel that their privacy is respected in the workplace, they will feel more satisfied with their work. In this way, they will perform much better at work. If employees' privacy isn't respected in the workplace, it will be difficult for them to get along with colleagues, which will make more employees think of hoping.

The door in this design best reflects the issue of privacy that exists in the workplace. Based on the design of door, colleagues cannot see each other all the time. Privacy in real life is divided into two types, auditory privacy and visual privacy. Auditory privacy is where one cannot hear others and where one cannot be heard by others. Visual privacy, on the other hand, means that one cannot see others, nor cannot be seen by others.



Figure 2.2 Project WC Who Cares

Source: Dutch Design Week, 2021

### 2.2.3 Hush felt pod Project Analysis

Figure 2.3 shows the Hush felt pod that is designed based on the concept of creating a closed space, a provided private space for rest. When we are in personal private space, we can not only take control of our surroundings, but also control the experience it brings. Its shape is similar to that of the uterus and is used to simulate the pacification of infants and young children. In this enclosed space, the employees may lie down and enjoy a moment of serenity. Its cushions made of wool blankets can be used to improve overall comfort. It is worth mentioning that the wool felt used is an environmentally friendly product that is recycled and reused. These two ways of use are changeable and can be folded down from the top to become an open seat (Buckle, 2013).

As the private space, it provides respite for our life or work. As a living being, we always have emotions present, and no matter what stage we are in, we need a

comfortable sanctuary, where tension can be removed or reduced. Especially when you are in a space where you can control your surroundings, it makes people feel more comfortable.



Figure 2.3 Project Hush felt pod

Source: Buckle, 2013

#### **2.2.4 Work bays VITRA Analysis**

A grid is used to divide different areas. The grid acts as a partition so that multiple functional spaces are separated. Besides, different shapes of seating units can be added to the grid frame, so that the needs of different spaces can be met (Dezeen, 2020).



This partitioned unit workshop is made of aluminum strips and pressed sound-absorbing cotton to form a lightweight wall (Figure 4), which reduces noise and provides a space that is isolated from the surroundings. With simple installation and the combined integration space, it can be assembled, expanded, or adjusted based on different requirements. It can be set anywhere in the workplace without any damage to the interior of the building. It redefines the working environment and breaks the typical planning structure of the office. It is a multifunctional unit space equipped with a workbench, seat, and storage.

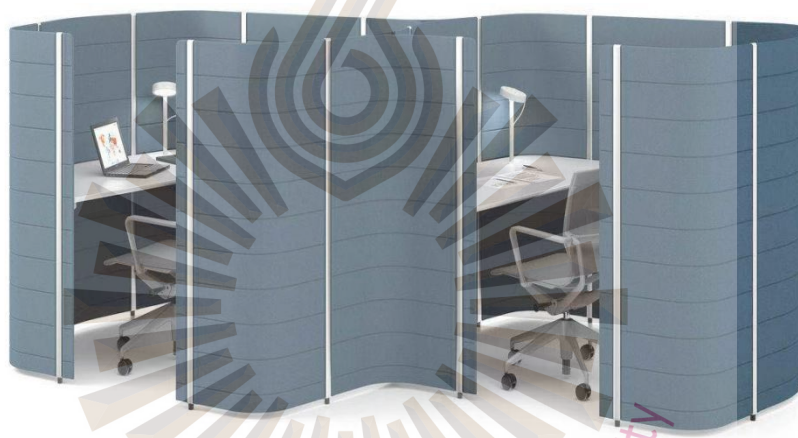

Figure 2.4 Work bays VITRA

Source: Dezeen, 2020

## Chapter 3

### Research Methodology

Researches on user needs, problems encountered by employees in the office, and through reading and data collection, it is discovered how users' needs relate to the office environment. In order to know about the problems that employees encounter in the office environment, social media also works as an assistance to collect opinions and suggestions, and to propose that the workplace should be completely closed.

#### 3.1 Investigate and observe data

20 people were interviewed by using the questionnaire survey. The question was asked about what kind of space relaxes you and what you think are the most important elements needed in this space. Through collating data, it was observed that good ventilation comfortable seating and quietness were the elements that account for a relatively large proportion. A small number of participants also considered it important to have light music and sweet food, which proved that the senses of sight, hearing, touch and smell are essential sensory experiences. Every element in the space can be conveyed in the form of certain kind of message.

Table 3.1 The list think are the most important elements needed in this space.

Item	Number
Scenery	4
Ventilation	12
Decoration	8

Table 3.1 The list think are the most important elements needed in this space(Continue)

Sweets	4
Comfortable Seat	16
Network	4
Light	8
Quietness	16
Light Music	4
Clean	8

## 3.2 Design evolution and thinking process

### 3.2.1 Size Analysis

Studies have proved that closed small space can effectively control emotions.

As above, a relatively closed environment is safe and easier to express true emotion. The design is based on the meaningful of a curved shape and a line which bring about the emotional associations. The slowly changes of curve provides a sense of balance and stability. Therefore, arc can also be called as a neutral line since it has no edges and corners. It is easier to soothe emotions and allows people to feel comfortable and at ease. The use of circles and arcs creates a breathing space, and the size of the circles and the denseness of the arcs can also be used to create a peaceful emotional feeling (Xia, 2019).

According to adult body size data, 95% of men apply a scale of 1795 millimeters and 1659 millimeters for women, which also meets the scale for an adult to walk upright in this space. The height is set to 1900 mm and the interval between the general floors is 2600 millimeters, which can be placed in the office space (Figure 3.1).

The thickness of the bottom plate is set to 50, with the bearing capacity taken into account. The inner-circle space diameter of human activity is set to 700 millimeters and the reference human traffic scale is 600 millimeters (Figure 3.2).

For the single seat, the seat height x depth x width is 410 x 430 x 450 millimeters and has three boards. The first block at 410 has a thickness of 20 millimeters while the second block at 930 is a backrest of 1450 millimeters.

There are only two pieces between partitions and there is no seating plate. The first block is at 930 and the second block is at 1450, which is between 930 and 1450 in line with the most comfortable access range between 960 and 1500. Dimensional data refer to ergonomics.

The width of the door is referred to the shoulder width of the person (Li, 2019).

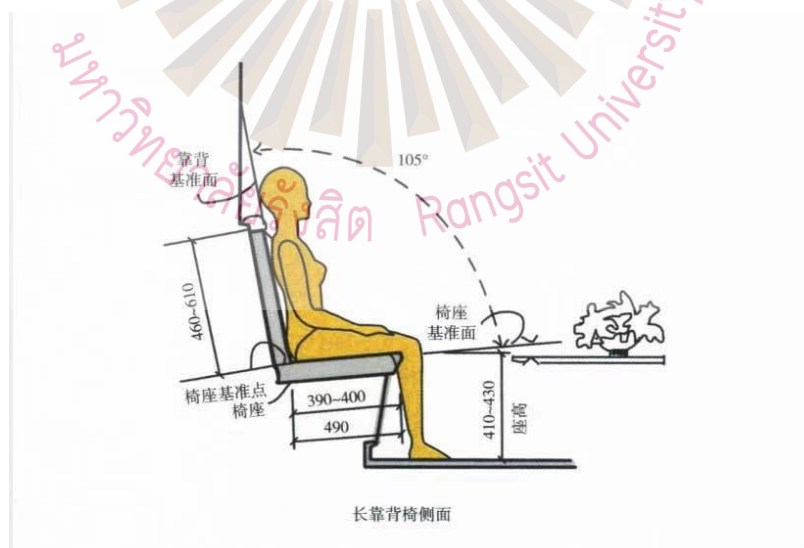

Figure 3.1 Data reference of chair

Source: Wendy, 2016



Figure 3.2 Data reference for cabinet

Source: Wendy, 2016

The Make pod is a seating unit that is fully enclosed as shown in Figure 3.3. If the space is occupied by a large number of population, it can bring crowded feeling. When we feel crowded, we may generate a sense of pressure, as if our private sphere is being invaded.

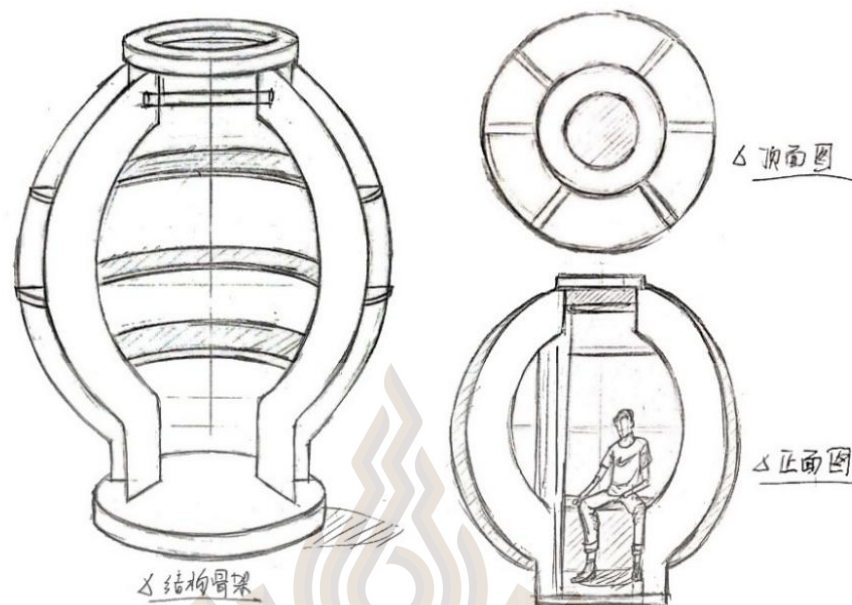

Figure 3.3 The sketch of a seating pod with a closed shape

To verify the feasibility of the dimension and the rationality of sketching, a model of 1:100 was made from wood blocks as shown in Figure 3.4.



Figure 3.4 Model of 1:100

The actual size display of 1:1 is also made. The computer software was used to create a layout of the 1:1 model (Figures 3.5 and 3.6).

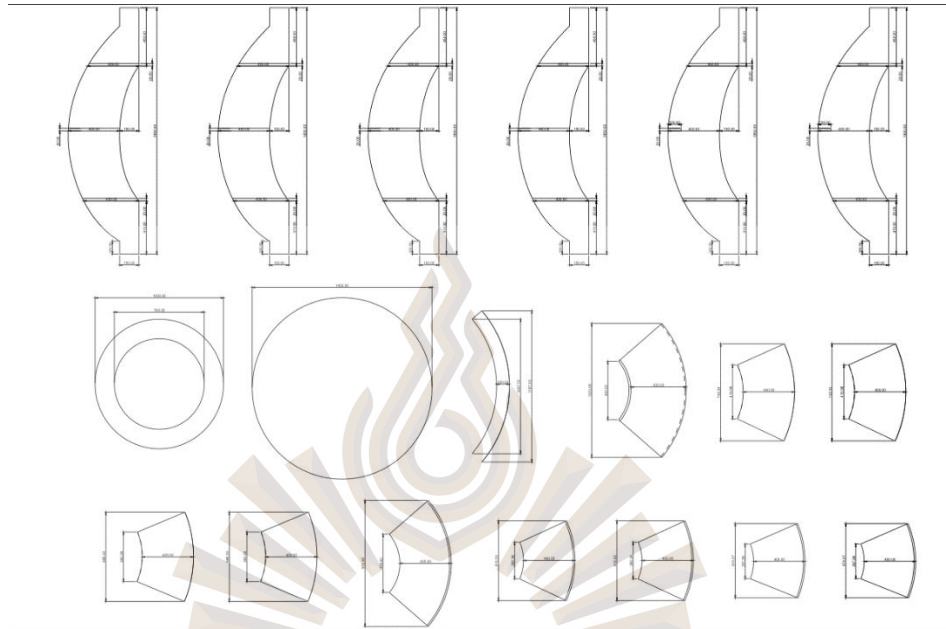

Figure 3.5 3Dimensional drawing of each part

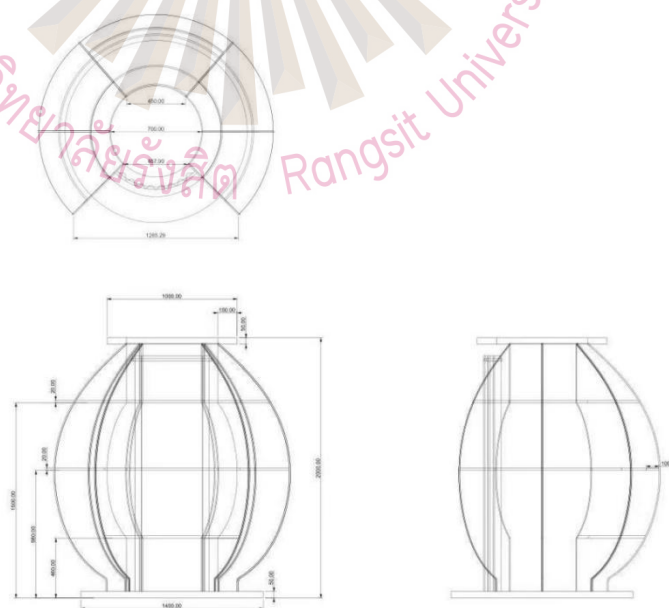

Figure 3.6 three dimensional view

### 3.2.2 Materials and Methods

The selected materials are wood and leather. Wood is a natural material with natural affinity (Figure 3.7). Besides wood is breathable, warm in Winter and cool in Summer. Wood does not only exude a simple meditation atmosphere but also inspires an open-minded and confident mood. Most importantly, the touch of wood is more gentle than that of metal.



Figure 3.7 Example of wood as a material used

Source: Busmano, 2020

The use of color has the lowest influence on muscle tension (Figure 3.8). Beige is the main color of the wall. According to the application skills of the fabric, leather has an expressive tactile method, wrinkle-resistant, abrasion-resistant, soft, stiff, and easy to shape (Figure 3.9).





Figure 3.8 Example of leather as a material used

Source: Busmano, 2020

Light Tonus		
Hue	measured value	reaction
Normal	23	Relaxation
Beige	23	
Blue	24	
Green	28	tension excitement
Yellow	30	
Orange	35	
Red	42	

Figure 3.9 Color psychology

### 3.2.3 Prototype of the design

The top surface is opened to improve air circulation, so the product has good ventilation and to ensure that light exposure for artificial lighting. The curved curtain made of cloth is designed as a movable entrance. The groove at the bottom is for preventing the damage probably occurred from dragging and avoiding the light penetration into the pod. The curtain can be inside locked to prevent someone from outside which ensures the privacy of the user as shown in (Figure3.10.) The periphery

of the pod is surrounded by cloth and wood which is invisible from the outside for keeping the completely privacy.

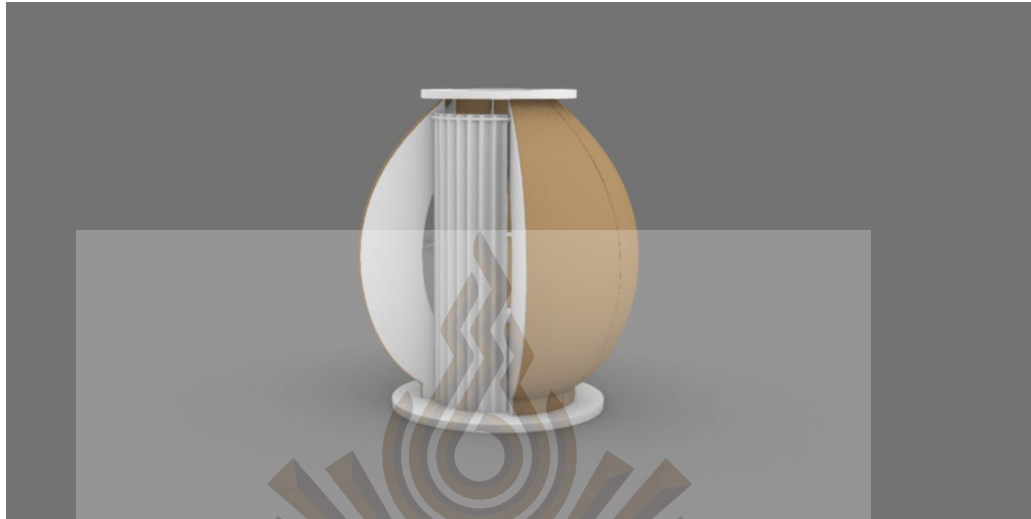

Figure 3.10 The 3D design of the exterior

It is a breathing space designed from the perspective of vision to help the employees adjust their emotions. It is impossible to use only one sense in this space and vision must be accompanied by the appearance of other senses. The interior is divided into two areas: a seating area and a storage area (Figure 3.11).

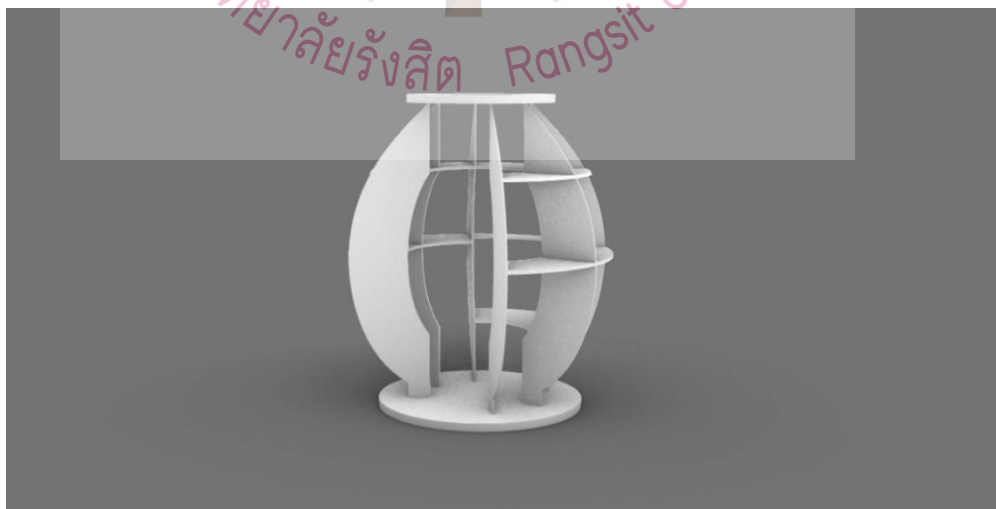

Figure 3.11 The 3D design of the exterior

The latter is suitable for placing books, magazines, plants, and fragrances. The sense of smell will induce emotional associations (Figure 3.12).



Figure 3.12 The computer design of the prototype showing the circumstance of the designed seat

## Chapter 4

### Final Design

#### 4.1 Product Details

The smell of ink on the book creates a space that makes the users feel confident and full of energy. Touching the plants makes the employees feel the humidity on the stem of the plant (Figure 4.1). The placement of green plants will undoubtedly improve the comfort of the space and make people calmer. Yucca and lilies are also plants that help to absorb carbon dioxide in the air and provide a cleaner air environment. Besides, the aroma of the plants with relaxing functions can also be used, especially lavender that has a soothing and calming effect, and lilies can also increase the excitement of the central nervous system, thereby creating a breathing space for the sense of smell.



Figure 4.1 Storage area supporting various usage of the designed seat

In the sense of touch (Figure 4.2), the interior is divided into two areas: the seating area and the storage area. Seat and backrest surfaces are covered with softer materials. Plants are placed to soothe emotions in the storage area. The seating area is provided with soft pillows. As important as touch is hugging, both tactile needs are inherently rooted in the expression of skin hunger. Touching and hugging are ways of human spiritual comfort, and hugging is the most emotional soothing agent. A person who has not been hugged and touched for a long time will gradually develop feelings of indifference and loneliness.

The taste experience is a kind of icing on the cake in the space, you can put chewing gum or chocolate to relieve tension. Chewing gum relieves tension by constantly chewing up and down to release stress at work. While chocolate is rich in magnesium, which has a calming and antidepressant effect, and the happiness and good feelings produced by taste go beyond the food itself. The sweetness of candy makes people feel safe. After tasting the sweetness, it promotes the brain to secrete chemicals that help people balance body and mind, making them happier and reduce stress. The right amount of food and space will be combined to create more space for fun. A good environment has a strong healing effect on bad emotions.



Figure 4.2 The seating area incorporated with storage areas,  
which provide more comfortable space

Here is its design. The seat can relax and release emotion better (Figure 4.3). The periphery is closed. When an employee enters this enclosed space, their behavior and actions are invisible from the outside, which ensures privacy (Figures 4.4 and 4.5)



Figure 4.3 The mockup illustrating how to use the designed seat



Figure 4.4 A prototype of the seat and its interior design



Figure 4.5 A prototype showing how to relax with the design seat

Space is modular. The periphery is wrapped to form a closed seating unit with a mild beige color visually. In the divided area or the seating area, there are soft pillows and backs. Comfortable cushions help you sit more comfortably. On the other

hand, the objects in the storage area combine the sense of smell, touch, and taste. All these elements come together to perfect the space (Figure 4.6).

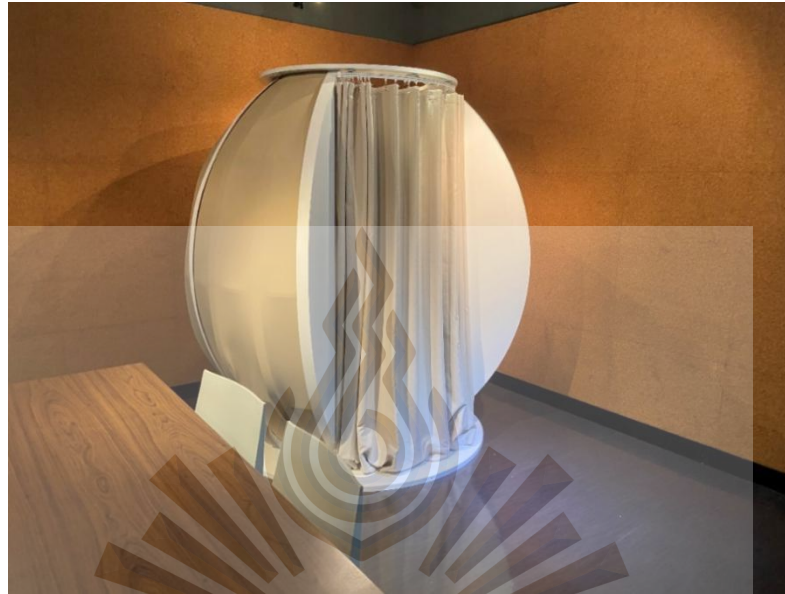

Figure 4.6 The finished prototype of a seating unit pod that is fully enclosed

## 4.2 Product application and future development possibilities

This study proposed a design of seating pod aiming to be a breathing space for users. The design focuses on finding opportunities to help the workforce recent and readjust the mood. The user's privacy is the primary target followed by the combination with a moment of respite where user will have their breathing space. It is also worth considering a peace place when staying alone.

The enclosed seating is designed to be completely customized to a person's size. The pod can be shared among several employees, so the inside decoration can be changed and cleaned regularly. Also, it can be adjusted according to seasons or company styles where one can take relaxation or meditation.



As a public space for everyone, this product is suitable to be placed in office. Enterprises can purchase this product and put it in their offices to add a rest area for their employees who need to stay alone in the public space and to help their employees relax to improve their working efficiency.



## **Chapter5**

### **Conclusion and recommendations**

#### **5.1 Conclusion**

Space is modular. The periphery is wrapped to form a closed seating unit with a mild beige color visually. In the divided area, in the seating area, there are soft pillows and backs. Comfortable cushions help you sit more comfortably. On the other hand, the objects in the storage area combine the sense of smell, touch and taste. All these elements come together to perfect the space.

To relieve people's stress, they need to be extracted from their current situation. The breathing space for the office workers can help them rest and relax for a while, adjust their emotions, and get back to work, and on the other hand, draw their attention to mental health caused by mood.

## References

- Augustin, S., Frankel, N., & Coleman, C. (2013). *Place Advantage: Applied Psychology for Interior Architecture*. US: Publishing House of Electronics Industry.
- Buckle, H. (2013). *Hush by Freyja Sewell*. Retrieved from <https://www.dezeen.com/2013/05/27/hush-felt-pod-by-freyja-sewell/>
- Dezeen. (2020). *Grid by Ronan and Erwan Bouroullec for Established & Sons*. Retrieved from <https://www.dezeen.com/2020/08/06/grid-ronan-erwan-bouroullec-established-sons/>
- Li, X. (2019). *Dimension Parameter of Interior Design*. Beijing, China: Chemical Industry Press.
- Paul Cocksedge Studio. (2019). *Please be seated*. Retrieved from <http://www.paulcocksedgestudio.com/please-be-seated>
- Simpkin, T. (2020). *Mixed feelings: how to deal with emotions at work*. Retrieved from <https://www.totaljobs.com/advice/emotions-at-work>
- Tual, L. (2020). *WC Who Cares interactive installation*. Retrieved from <http://lolatual.eu/index.html>
- United Nations. (2018). *Department of Economic and Social Affairs*. Retrieved from <https://www.un.org/development/desa/en/news/population/2018-revision-of-world-urbanization-prospects.html>
- Xia, R. (2019). *Emotion Space: Spatial psychology*. China: Jiangsu phoenix science and technology press.

## Biography

Name	Qing Liu
Date of birth	May 28, 1997
Place of birth	Hu Nan, China
Education background	Zhejiang Normal University, China Bachelor of Arts, 2019 Rangsit University, Thailand Master of Fine Arts in Design, 2021
Address	AKE Apartment, Lak Hok, Mueang Pathum Thani District, Pathum Thani 12000, Thailand
Email Address	liuqingdeem@gmail.com

